

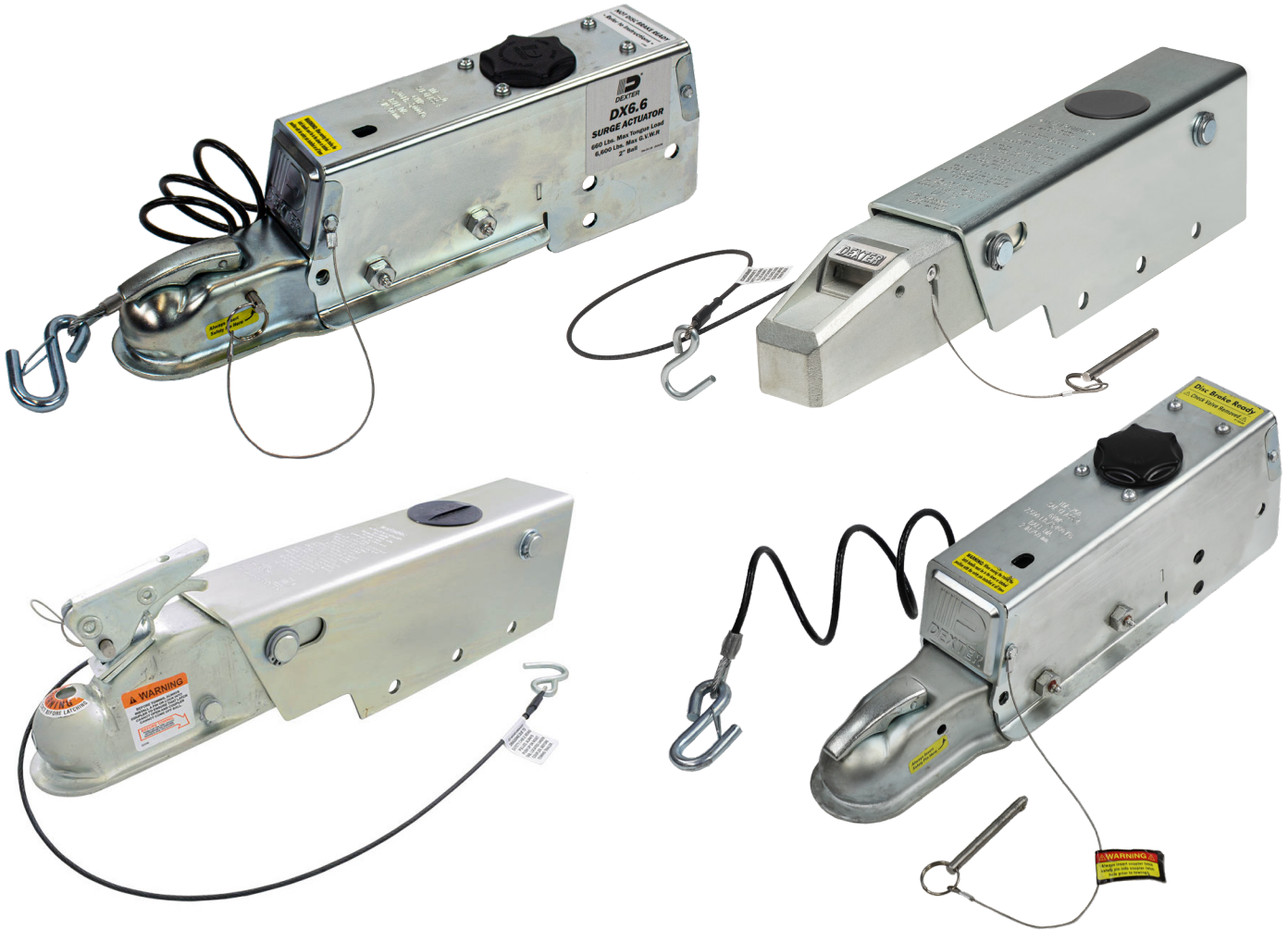

# SURGE ACTUATORS

HYDRAULIC SURGE BRAKE ACTUATION



## INSTALLATION MANUAL

### LIGHT DUTY ACTUATORS

6,600 - 8,500 LBS. CAPACITY

[www.dexteraxle.com/surgeactuators](http://www.dexteraxle.com/surgeactuators)

## TABLE OF CONTENTS

### SECTION 1 - PRODUCT IDENTIFICATION

1.1 - STANDARD PROFILE .....	3
1.2 - LOW PROFILE .....	3

### SECTION 2 - IMPORTANT INFORMATION

2.1 - BRAKE REQUIREMENTS .....	4
2.2 - TOWING/HITCHING REQUIREMENTS .....	4

### SECTION 3 - INSTALLATION

3.1 - BOLT-ON (STANDARD AND LOW PROFILE).....	5
3.2 - WELD-ON (LOW PROFILE) .....	5
3.3 - CONNECTING THE REVERSE SOLENOID .....	6

### SECTION 4 - BRAKE BLEEDING

4.1 - STANDARD PROFILE .....	6
4.2 - LOW PROFILE .....	7

### SECTION 5 - TRAILER HITCHING

5.1 - DROP-N-GO™ COUPLER .....	7
5.2 - MANUAL AND LEVER LOCK COUPLER.....	7

### SECTION 6 - BEFORE TOWING

6.1 - EMERGENCY BREAKAWAY CABLES.....	8
6.2 - ROAD TESTING .....	8
6.3 - TOWING CONSIDERATIONS.....	8



## SECTION 1 - PRODUCT IDENTIFICATION

There are two types of actuators referenced in this document. While mostly similar, there are places where they have separate instructions. These actuators are designed to fit 3" wide tongues in heights of 3", 4", and 5".

Throughout the manual, actuators will be referred to their groupings listed below.

### 1.1 - STANDARD PROFILE

**DX6.6  
DROP-N-GO™**



G.V.W.R.: 6,600 LBS.  
TONGUE WEIGHT: 330 - 660 LBS.  
BALL SIZE: 2" AND 50MM

**DX7.5  
DROP-N-GO™**



G.V.W.R.: 7,500 LBS.  
TONGUE WEIGHT: 375 - 750 LBS.  
BALL SIZE: 2" AND 50MM

**DX8.5  
DROP-N-GO™**



G.V.W.R.: 8,500 LBS.  
TONGUE WEIGHT: 425 - 850 LBS.  
BALL SIZE: 2"

### 1.2 - LOW PROFILE

**DX7.5L  
MANUAL COUPLER**



G.V.W.R.: 7,500 LBS.  
TONGUE WEIGHT:  
375 - 750 LBS.  
BALL SIZE: 2"

**DX7.5L  
LEVER LOCK COUPLER**



G.V.W.R.: 7,500 LBS.  
TONGUE WEIGHT:  
375 - 750 LBS.  
BALL SIZE: 2"

**DX8.5L  
DROP-N-GO™**



G.V.W.R.: 8,500 LBS.  
TONGUE WEIGHT:  
425 - 850 LBS.  
BALL SIZE: 2"

**DX8.5L - 2-5/16"  
DROP-N-GO™**



G.V.W.R.: 8,500 LBS.  
TONGUE WEIGHT:  
425 - 850 LBS.  
BALL SIZE: 2-5/16"

**DO NOT EXCEED THE MAXIMUM TONGUE WEIGHT RATING OF YOUR TOW VEHICLE OR ITS HITCH SYSTEM.  
EXCESSIVE TRAILER TONGUE WEIGHT CAN NEGATIVELY AFFECT TOW VEHICLE BRAKING AND HANDLING.**

## SECTION 2 - IMPORTANT INFORMATION

READ AND UNDERSTAND THE ENTIRE PROCEDURE BEFORE INSTALLATION OF THIS PRODUCT. THIS MANUAL APPLIES TO AFTERMARKET SURGE ACTUATOR INSTALLATION AND IS NOT MEANT TO ASSIST IN NEW TRAILER DESIGNS.

### CAUTION

FAILURE TO PROPERLY MAINTAIN THE ACTUATOR ACCORDING TO THE SERVICE MANUAL COULD LEAD TO DAMAGE, INJURY OR DEATH.

Surge actuators work by the “surge” or “push” of the trailer toward the tow vehicle. This automatically synchronizes the trailer brakes with the tow vehicle brakes. When the trailer pushes against the tow vehicle, the actuator telescopes together and applies the force to the master cylinder, supplying hydraulic pressure to the trailer brakes.

Review and understand the manufacturers’ manuals for your tow vehicle and trailer before installation. The user is responsible for the consequences of inadequate maintenance, deliberate misuse, alteration, or damage to the actuator.

If corrosion is present on the actuator, replace the metal brake lines and/or hoses due to metal corrosion or rubber breakdown.

### CAUTION

DO NOT LIFT OR SUPPORT THE TRAILER ON ANY PART OF THE AXLE OR SUSPENSION SYSTEM. NEVER GO UNDER ANY TRAILER UNLESS IT IS PROPERLY SUPPORTED ON JACK STANDS WHICH HAVE BEEN RATED FOR THE LOAD. IMPROPERLY SUPPORTED VEHICLES CAN FALL UNEXPECTEDLY AND CAUSE SERIOUS INJURY OR DEATH.

## 2.1 - BRAKE REQUIREMENTS

This actuator is part of a complete trailer hydraulic brake system. When replacing an actuator, ensure you replace it with the correct system to match the brakes. Drum brake actuators cannot be used on disc brake trailers and vice versa. Disc brake actuators also require an electric solenoid. Drum brake actuators must be used with free-backing drum brakes.

State brake laws are minimum standards. Dexter recommends having brakes on all axles.

### CAUTION

DO NOT USE AN ACTUATOR AS A PARKING BRAKE.

## 2.2 - TOWING/HITCHING REQUIREMENTS

Using the correct hitch ball size is critical to the safe operation of your trailer. Use the chart in the actuator identification section to ensure the correct fit. DO NOT use a multi-piece ball, an incorrectly sized ball, or a worn/damaged ball.

Before each trip, inspect the hitch ball, coupler latch, and safety chains for wear, corrosion, or damage. Repair or replace components per manufacturer’s instructions as necessary.

### CAUTION

INCORRECT OR DAMAGED TOW BALL USAGE COULD LEAD TO A TRAILER SEPARATION FROM THE TOW VEHICLE, RESULTING IN DAMAGE, INJURY, OR DEATH.

Any control devices that restrict the operation of the actuator cannot be used including certain sway control devices. The actuator must be free to telescope in response to braking signals.

Equalizing or weight-distributing hitches that are designed to be used with surge brake actuators may be utilized and must allow 6-8” free chain length.

### CAUTION

ALWAYS INSERT THE COUPLER LATCH SAFETY PIN INTO THE CORRECT HOLE BEFORE TOWING. DO NOT TOW THE TRAILER IF THE COUPLER IS DAMAGED.

Review the trailer and tow vehicle manufacturers’ manuals for information on towing capacity, trailer brake requirements, weight-distributing hitches, and other towing recommendations.

The user is responsible for ensuring the tow vehicle and towing components are rated to match the trailer G.V.W.R.

The actuator may not function properly if the trailer is not level. To ensure the trailer is level, the trailer tongue should be parallel to the ground.

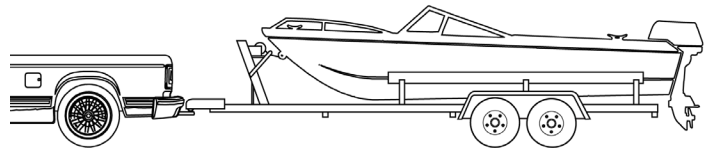

There are no adjustments on the actuator. Do not attempt to adjust or modify the coupler latch in any way to compensate for wear, damage or to fit a tow ball. The Model DX7.5L A-75 actuator has a locknut underneath its coupler latch that is factory set. Do not attempt to adjust the nut setting.

## SECTION 3 - INSTALLATION

### 3.1 - BOLT-ON (STANDARD AND LOW PROFILE)

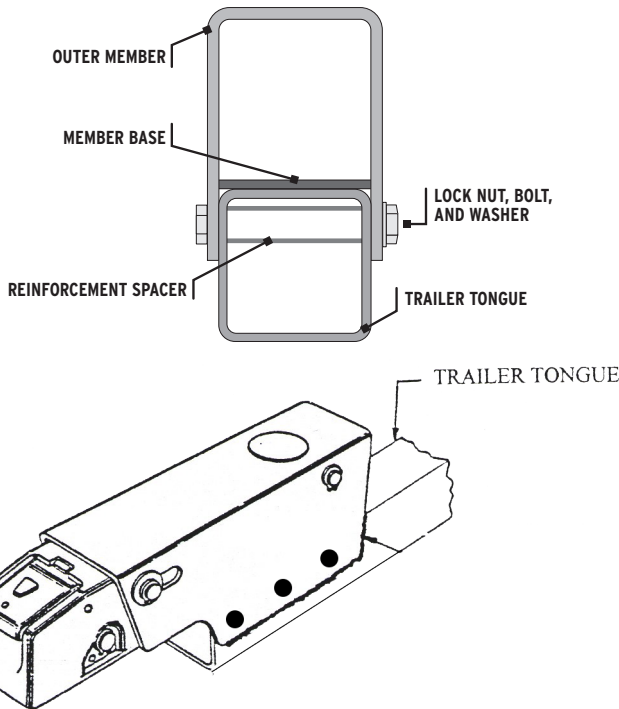

1. These actuators are completely assembled and ready to bolt on using 1/2" x 4" grade 5 bolts, not included.
2. Torque the bolts and locking nuts to 80 ft.-lbs.
3. Spacer tubes for reinforcement are required on tongues less than 3/16" thick. Attachment hardware needs to be rated at least 150% of G.V.W.R. of trailer.
4. Route and install brake lines following brake manufacturer's instructions. Flexible lines may be necessary in certain cases.
5. For trailers with a reverse solenoid, move to section 3.3. For all other trailers, move to section 5.

### 3.2 - WELD-ON (LOW PROFILE)

1. Weld according to AWS specifications. Welder must wear appropriate personal protective equipment and meet AWS qualifications. Ensure that the welding location allows access to wiring and brake lines for service.
2. Remove inner member subassembly, then weld outer member to trailer tongue using the following diagrams.
3. Reinstall inner member.
4. Route and install brake lines following brake manufacturer's instructions. Flexible lines may be necessary in certain cases.
5. For trailers with a reverse solenoid, move to section 3.3. For all other trailers, move to section 5.

#### Top Mount Welding

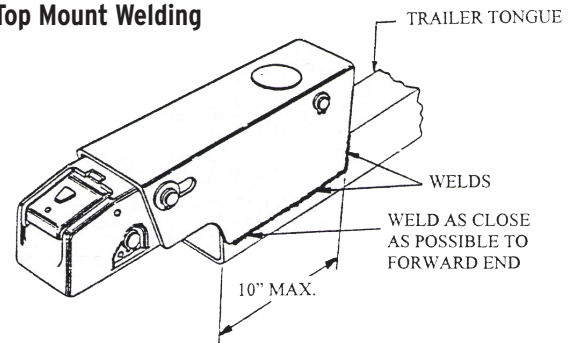

#### In-line Welding

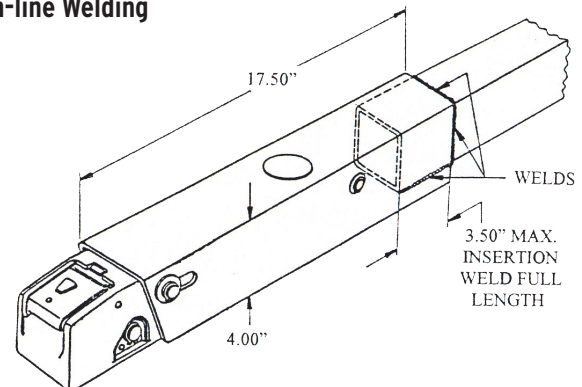

In-line welding needs to allow the inner slide, master cylinder, and solenoid to slide rearward during operation.

#### A-Frame, Short Tongue

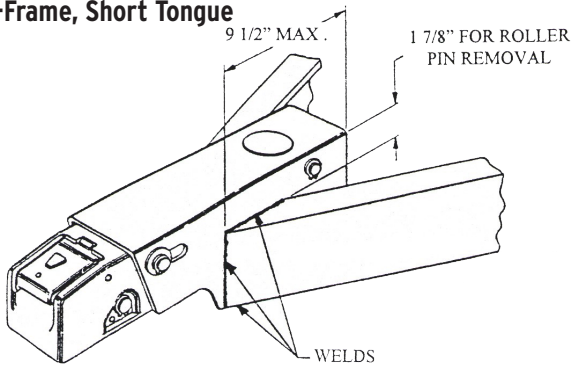

#### A-Frame, Tall Tongue

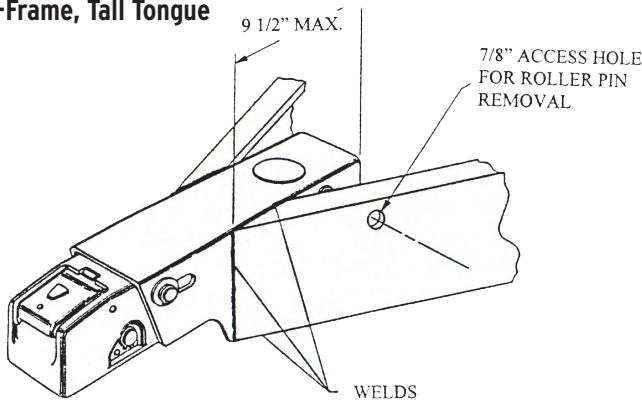

A-Frame trailers may require additional structure to withstand the torsional twist during actuator use. The cross member should be installed as close to the actuator as possible.

### 3.3 - CONNECTING THE REVERSE SOLENOID

Disc brake actuators come standard with a reverse solenoid. By using the reverse lights of your tow vehicle, it eases the process of backing up the trailer.

You can add an aftermarket reverse solenoid to a drum brake actuator as well. Follow manufacturer's instructions.

1. Attach brake line to solenoid. Do not use thread sealant on this connection.
2. Attach one of the two leading wires to the center pin of the trailer connector (usually yellow or purple wire).
3. Ground the remaining solenoid wire to the trailer frame.
4. Ensure the center pin of the 7-way connector is attached to reverse lamp circuit.

**⚠ CAUTION**

CONNECTING TO THE WRONG PLUG WILL CAUSE THE BRAKES TO FAIL

## SECTION 4 - BRAKE BLEEDING

For ease of bleeding the system, keep the actuator lower than the disc brake calipers if possible.

Ensure brake lines do not slope up before slopping down, trapping air. Ensure bleeder screws on the brake calipers are on the top side of the caliper before beginning.

**⚠ CAUTION**

DO NOT REUSE BRAKE FLUID. ALWAYS USE FRESH DOT 3 FLUID FROM A FRESH CONTAINER. FAILURE TO MAINTAIN PROPER LEVELS OF FLUID IN THE RESERVOIR WILL CAUSE BRAKE FAILURE.

Start the bleeding process at the brake located at the farthest point along the brake line routing from the surge actuator.

If using a pressure bleeder, follow the manufacturer's instructions. The pressure in the power bleeder should not exceed 18 psi. Exceeding this pressure will damage the diaphragm in the master cylinder reservoir, causing it to leak.

Set up the area with a clear container filled with clean brake fluid. Ensure that the end of the bleeder hose can be completely submerged to prevent air from traveling back into the system. NEVER REUSE THIS FLUID.

Constantly check brake fluid levels when bleeding as the reservoir can quickly run out and put air in the lines. If this occurs, the process will need to start over.

## 4.1 - STANDARD PROFILE

1. Ensure that the bleeding access port matches Figure 4A before pumping. If it looks like 4B, gently push on the coupler until you can see the rounded corner of the e-stop bracket.



Figure 4A:  
Correct access hole



Figure 4B:  
**INCORRECT** access hole

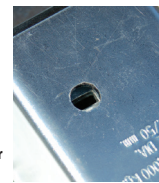

↑  
Actuator  
Tongue  
Insert  
screwdriver  
tip here

2. If you can't see the rounded corner of the emergency breakaway bracket (fig. 4B) through the access port, gently push the coupler forward. Do not place a screwdriver in the access port until the rounded edge of the e-stop bracket can be seen through the port(fig. 4A).
3. Place the tip of a flat screwdriver in front of the e-stop bracket (fig. 5A).

Figure 5A:  
Correct screwdriver tip position

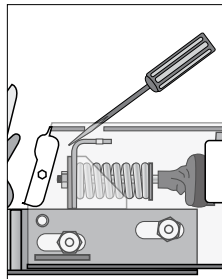
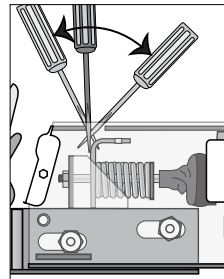

Figure 5B:  
Master cylinder pumping



4. While keeping pressure, pump the master cylinder using the screwdriver (fig. 5B). Crack the bleeder valve open and tighten. Repeat until there are no more air bubbles.
5. The screwdriver should be at the lowest angle possible to the actuator so that it slides in front of the e-stop bracket (Fig. 5A).
6. Push the screwdriver forward and back to pump the master cylinder (fig. 5B).
7. The bleeding operation for that brake is complete when bubbling stops. Be sure to tighten the bleeder screw securely. Each wheel cylinder must be bled until all air is out of the lines.
8. Replenish the brake fluid during the bleeding process so the level does not fall below half full level in the master cylinder reservoir.
9. Continue on to section 5.

## 4.2 - LOW PROFILE

Two people are required for this operation.

1. Remove the master cylinder reservoir plug and fill the reservoir with brake fluid. Fluid will need to settle until completely free of air bubbles.
2. Bleed the actuator master cylinder by inserting a screwdriver through the hole of the inner member button. Use short strokes to pry on the pushrod (while holding the safety release bracket up) until no air bubbles are seen coming from a small orifice hole in the bottom of the master cylinder reservoir.
3. The first person slowly strokes the pushrod while holding the safety release bracket.
4. The second person opens the bleed screw fitting, then closes the bleed screw fitting **BEFORE** the first person **SLOWLY** releases the pushrod. Repeat this procedure until the fluid expelled from the bleeder hose is free of air bubbles.
5. Remember to always tighten the bleeder screw before releasing the pushrod. During this procedure, the master cylinder reservoir fluid level must be maintained at no less than half full.
6. Repeat steps 4 and 5 for the brake on the other side of the axle. Then repeat on any additional axle sets for tandem or triple configurations.
7. Repeat rear axle bleeding on multiple axle configurations to ensure air is out of the system.
8. Stroke the pushrod and check to be sure the brake system is pressurized by attempting to rotate a tire.
9. Push up on the safety release bracket to ensure that the pushrod is in a released position.
10. After bleeding has been completed, recheck the fluid level in the master cylinder. Fill the master cylinder reservoir to the indicator on the reservoir plug. Do not overfill.

## SECTION 5 - TRAILER HITCHING

### CAUTION

ENSURE YOU HAVE THE CORRECT BALL SIZE FOR YOUR COUPLER. A LOOSE FIT BETWEEN THE COUPLER AND HITCH BALL CAN CAUSE THE ACTUATOR AND HITCH BALL TO SEPARATE, CAUSING SERIOUS DAMAGE, INJURY OR DEATH. CHECK COUPLER EVERY TIME PRIOR TO TOWING. **COUPLER LATCH SAFETY PIN MUST BE SECURELY INSTALLED INTO COUPLER LATCH BEFORE TOWING.**

#### 5.1 - DROP-N-GO™ COUPLER

1. This coupler is self-latching and does not require the latch handle to be in the unlatched position to insert the hitch ball.
2. To latch coupler onto the hitch ball, position the tow vehicle so the hitch ball is directly under the coupler socket.
3. Make sure the hitch pin is removed from side of coupler.
4. Lower the coupler over ball. The coupler handle will remain in a horizontal position, but will rise and then self-latch and lower itself when the coupler is fully seated onto hitch ball.
5. If the hitch pin cannot be reinserted, the ball is not properly aligned or is damaged. DO NOT FORCE THE COUPLER TO LATCH. Replace ball if necessary. Once the handle is fully closed, insert hitch pin fully into hole on side of coupler.
6. Lightly lift up to see if coupler will lift to ensure it is completely latched.
7. Connect safety cables or chains using crossed pattern under tongue, or follow trailer manufacturer's directions.
8. Connect actuator breakaway cable S-hook to the tow vehicle only. Do not connect S-hook to the safety cables or chains.
9. The breakaway system is not a parking brake. It is designed to operate if the trailer and the safety cable/chains have failed.
10. Continue to section 6.

#### 5.2 - MANUAL AND LEVER LOCK COUPLER

1. Hitch trailer by placing coupler socket over the ball. Ensure that the ball is not underneath or pressing directly on the pawl/jaw of the coupler.
2. Lower coupler and close handle. Coupler handle should close with minimal force. If handle does not close, the hitch ball is not fully inserted into coupler socket, the hitch ball is oversized or egg-shaped. DO NOT FORCE HANDLE. Replace ball if necessary.
3. Verify that ball is completely inserted into coupler socket by looking into the hole on top of coupler body and the tow ball top can be seen just below the hole.
4. Verify that the latch handle, the plate below it, and the top of the coupler are all in contact. The closed latch should

rest on top of the plate, the plate then rests on top of the coupler nose when the latch is properly closed.

5. Lightly lift up to see if coupler will lift to ensure it is completely latched.
6. Insert hitch pin into hole on side of coupler latch handle. If the hitch pin cannot be reinserted, the ball is not properly aligned or is damaged.
7. Connect safety cables or chains using crossed pattern under tongue, or follow trailer manufacturer's directions.
8. Connect actuator breakaway cable S-hook to the tow vehicle only. Do not connect S-hook to the safety cables or chains.
9. Continue to section 6.



## SECTION 6 - BEFORE TOWING

### 6.1 - EMERGENCY BREAKAWAY CABLES

#### CAUTION

THE BREAKAWAY SYSTEM IS NOT A PARKING BRAKE. IT IS DESIGNED TO OPERATE IF THE TRAILER AND THE SAFETY CABLE/ CHAINS HAVE FAILED.

BEFORE TOWING, IT IS CRITICAL TO ENSURE THE EMERGENCY BREAKAWAY SYSTEM IS NOT ENGAGED.

#### STANDARD ACTUATORS:

The emergency breakaway stop button is located on the side of the actuator. Ensure it is in the normal operating position before towing.

#### Normal operating position

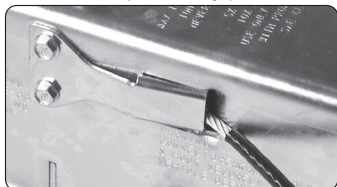

#### If button stop cable is showing DO NOT TOW TRAILER



#### LOW PROFILE ACTUATORS:

1. Locate the pushrod release tab on the underside of the actuator, just behind the coupler socket.
2. The pushrod release tab should push up with slight pressure and nothing else should happen. If you hear a noise, similar to a loaded spring releasing, this can be a sign that the trailer brakes were inadvertently set and the cause should be investigated.
3. If the pushrod release tab is jammed or is damaged, the emergency breakaway system needs serviced.

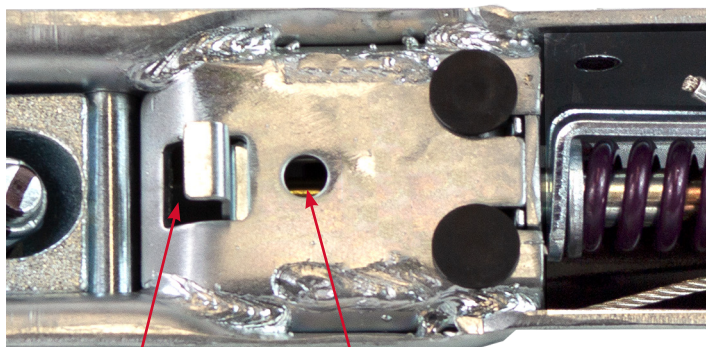

Pushrod Release Tab

Pushrod Access Hole

### 6.2 - ROAD TESTING

1. Ensure that trailer lights are operational.
2. Disconnect the trailer plug from tow vehicle. This will also disconnect the solenoid. Attempt to back up the trailer on a slight incline, which should be difficult or not possible if brake bleeding has been completed correctly. If you can reverse the trailer easily, there is still air in the brake system and the bleeding process will need repeated.
3. Additional step for low profile - pull trailer forward and stop suddenly, the actuator front slider pin should not travel more than halfway in slot for single axle or 3/4-way in slot for tandem axles.
4. After the initial trailer braking test, recheck fluid in the actuator and refill as necessary. If the master cylinder fluid is extremely low or dry after the bleeding process, the bleeding process will need to be repeated.
5. Check for leaks at all fittings and connections and tighten or correct as necessary. Properly dispose of fluid.

### 6.3 - TOWING CONSIDERATIONS

Avoid sharp turns and towing over large bumps as this can damage the actuator, trailer, or tow vehicle.

The actuator will not operate when backing down a hill, use caution as your tow vehicle brakes will be your only stopping power.

Brake and actuators can overheat and fade after periods of long braking. Take the time to learn the proper procedure for trailer braking before use.



# NOTES

## NOTES



**TOGETHER**  
CARRYING WHAT MATTERS MOST

**OVER 450+**  
**NORTH AMERICAN**  
**DISTRIBUTION**  
**LOCATIONS**  
**FOR ALL YOUR TRAILER PARTS NEEDS**



**FIND THE LOCATION CLOSEST TO YOU BY  
SCANNING THE CODE OR VISITING  
[WWW.DEXTERAXLE.COM/DISTRIBUTORS](http://WWW.DEXTERAXLE.COM/DISTRIBUTORS)**

**NO PART OF THIS MANUAL MAY BE REPRODUCED WITHOUT DEXTER'S PERMISSION.  
ALL PART NUMBERS, DIMENSIONS AND SPECIFICATIONS IN THIS MANUAL ARE SUBJECT TO CHANGE WITHOUT NOTICE.**