



# AUXILIARY SUSPENSIONS COMPLETE TRUCK SOLUTIONS



## INCREASED LOAD CAPACITY.

### CUSTOM DESIGNS TO MEET YOUR NEEDS

- » 8,000 - 20,000 lbs. capacities
- » Short mounting envelope allows for tighter axle spacing
- » Multiple air brake, frame width, profiles, and tire application options available

### QUALITY YOU CAN DEPEND ON

- » Urethane bushings at pivot points for unmatched durability
- » Integrated axle and suspension system reduces installation time
- » Over 60 years of suspension manufacturing experience

# AIR LIFT AXLE SYSTEMS

## » WORKS TOUGH

- Rigorously engineered to meet the rugged terrain and application wear your truck will encounter
- A higher pivot point means reduced frame rail stress, less maintenance, and unmatched stability
- Durable, low maintenance, pull arm and axle seat connections
- Integrated lift allows unloaded axle to be raised, reducing tire wear

## » COMPLETE SYSTEM

- Includes air brakes, hub-drums, lower cross member, and auto slack adjusters
- Steer and non-steer options
- Use as a pusher or a tag axle
- Adjustable frame widths and large ride height range for various truck configurations
- Compact dimensions for minimum frame space

## » STEER AXLE

- Coil spring steering dampers provide unsurpassed stability and driver control
- High strength, fabricated steering axle for single tire applications

## » NON-STEER AXLE

- Designed for use with Dexter's trusted 5" round heavy duty axle
- 6" or 8" Drop Center Axle options
- Custom solutions and standard 71.5" and 77.5" track axles available

## UF SERIES

8,000 - 13,200 lbs.  
Steer Axle

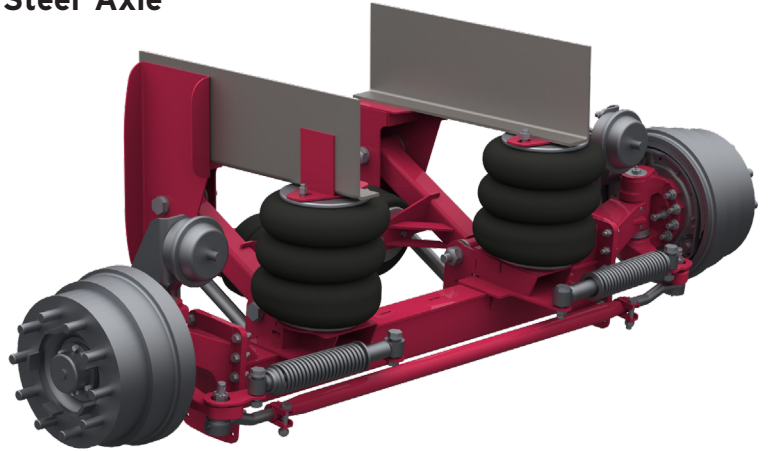

## AAS SERIES

13,200 - 20,000 lbs.  
Steer Axle

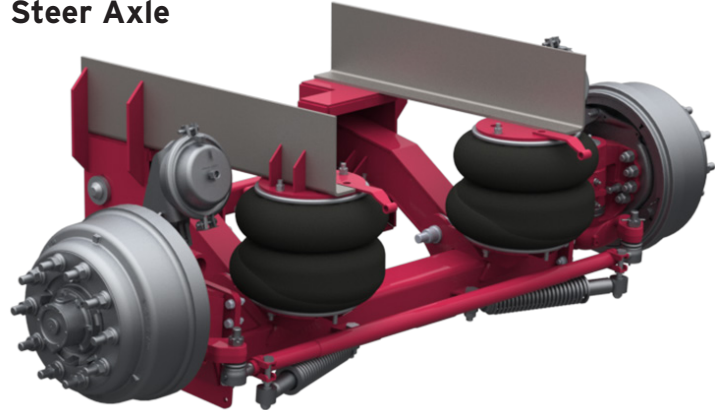

## AA SERIES

13,200 - 20,000 lbs.  
Non-Steer Axle

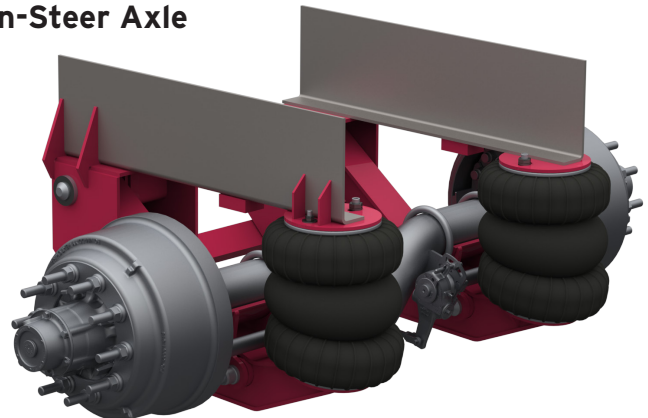

[www.dexteraxle.com](http://www.dexteraxle.com)

# ADDITIONAL UPGRADE OPTIONS

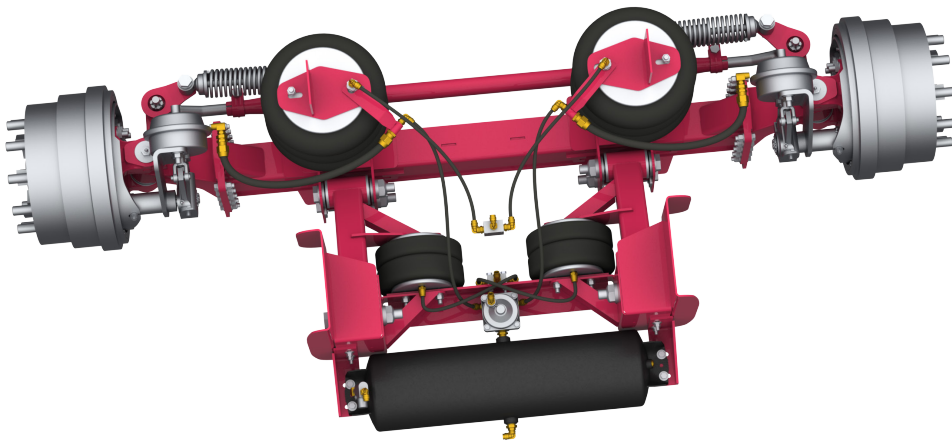

## » PRE-PLUMB KIT

- Air tank
- R-12 relay, brake protection, and quick release valves
- Brackets & Hoses Installed
- Pre-Installation available

## » AIR CONTROL

- Multiple outside cab regulator panel options
- Options for both in-cab and outside operation switches
- Auto-reverse lift option



SD-812 SHOWN



## » INSTALLATION KITS

- Airlines and fittings for SD-812 or AC-2000 controller
- R-12 relay valve kit with airlines and fittings included
- Mounting bolts and lock nuts
- Air tank



[www.dexteraxle.com](http://www.dexteraxle.com)



# INCREASED PRODUCTIVITY

## » MAXLE®

- Adds up to 12,000 lbs. payload per trip for increased revenue
- Hydraulic cylinders engage to create a rigid truck frame extension
- System comes ready to install
- Pre-wired for truck lighting hookups
- System raises and lowers using the same PTO as the truck body
- Modular unitized construction for reduced installation time and cost
- Steer axle provides better maneuverability, stability, and reduced tire wear
- Loading or dumping not effected when in the stowed position
- Dump body, crane truck and cement mixer applications

## » SYSTEM ALSO INCLUDES:

2,100 psi pre-charged accumulator  
Additional air tank, lines, cylinder, valve and control

Trailer lights, fenders and mud-flaps

Hydraulic cylinders, Solenoid, and Valve Block



MAXLE-CM

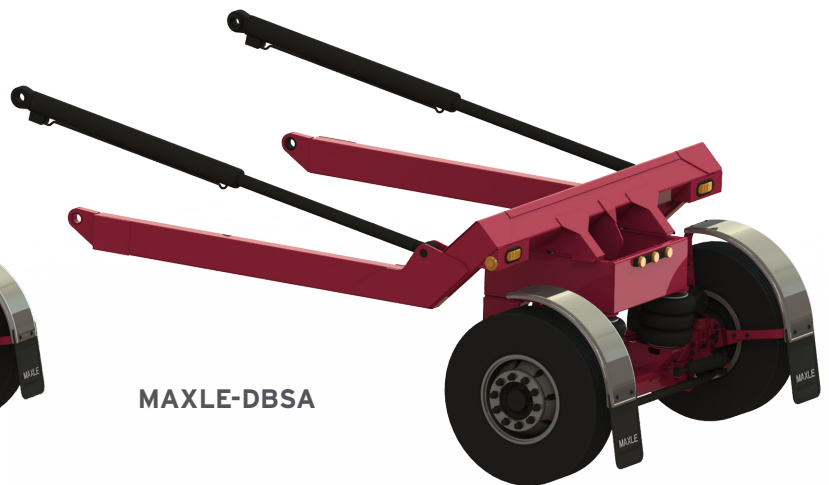

MAXLE-DBSA

[www.dexteraxle.com](http://www.dexteraxle.com)