

Date: June 17, 2016

## Subject: Spindle Nut Retention System

Dexter is pleased to announce a running production change to incorporate our unique patented spindle nut retaining system. The update will affect all 600 to 8,000 lb. standard grease and Ultralube equipped axles produced at the IAC plants.

The innovative bearing retaining system uses a unique concept to not only fine-tune the adjustment, while also simplifying the installation. The old, traditional method for securing trailer wheel bearings uses a castellated nut that is threaded on the spindle. The castellated nut was secured with a cotter pin inserted through a drilled cross hole. The cotter pin engages notches in the nut to prevent rotation and keep the nut in place. While this system has been used successfully for many years, it does not provide the same consistency found in the new system.

The new system uses a special hex nut and high strength spring steel retaining clip. Once the spindle nut is installed onto the spindle per instructions below, the retaining clip is simply snapped over the hexagonal outer surface of the nut while the formed tab engages the machined flat on the spindle to prevent rotation.

**CAUTION: The new jam nut is specially designed for this application. DO NOT attempt to use a standard SAE jam nut as replacement for the new Dexter 006-191-00 spindle jam nut.**

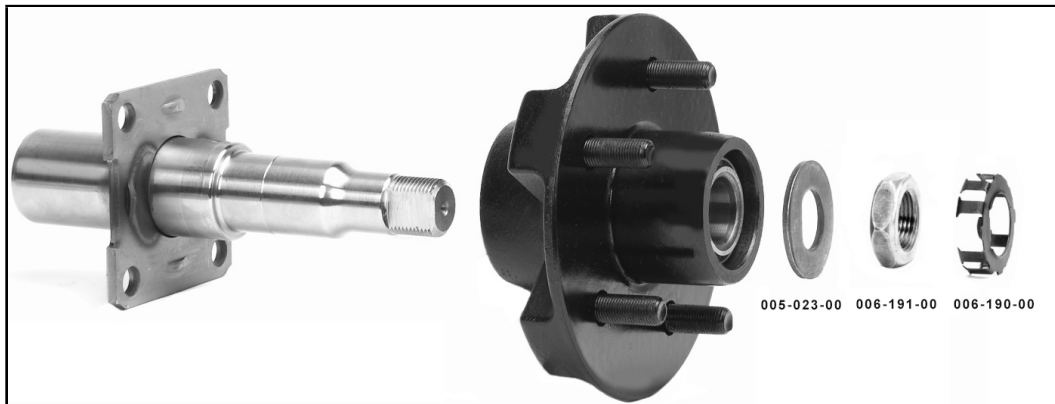

New Caged System

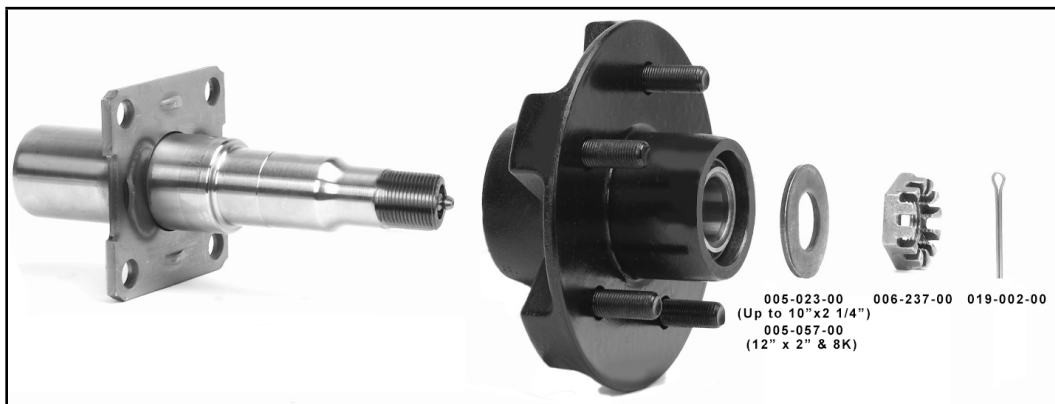

Cotter Pin System

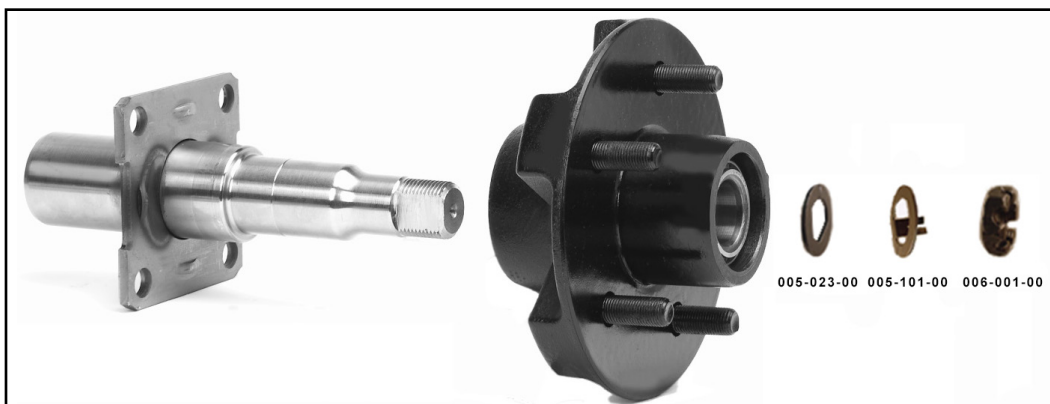

**“D-Flat” Retention System**

**Service Considerations:**

Axles built with “D-Flat” spindles (see picture) can be serviced with new parts. Axles built with offset cotter pins are not compatible with new “Caged” system, and will need serviced with like components.

Please note that #8, #9, or D20 axles built without a washer in between the spindle nut and outer bearing should not use the same washer in the New System. Adding a spindle washer is not recommended due to the lack of spindle length.

**Spindle Nut Kits**

Version	Part Number	Description
New Caged System	K71-622-00	Spindle Nut Retainer Kit
Cotter Pin System	K71-321-00	Nuts, Washers, & Cotter Pins 1,100 LB. to 8,000 LB.
“D-Flat” Retention	K71-335-00	Spindle Nut & Washers

**BEARING ADJUSTMENT METHOD USING NEW SYSTEM:**

1. After placing the hub, bearings, washer, and spindle jam nut back on the axle spindle, rotate the hub or hub-drum assembly slowly while tightening the spindle nut to approximately 50 lb-ft.
2. Then loosen the spindle jam nut to remove the torque. Do not rotate hub.
3. Finger tighten the spindle jam nut until it is snug.
4. Snap the 006-190-00 retainer clip over the spindle jam nut.

There will be no additional cost for this product enhancement.

Please contact your Dexter Sales Engineer with any questions.

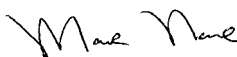

Mark Nave  
Market Manager