

Date: June 30, 2020

Subject: Airflex® Pivot Bushing Update

In keeping with our continual commitment to product innovation and industry safety, Dexter is pleased to introduce a more robust pivot bolt on the #12, #13, #13G and #13D Airflex axles. The pivot bolt and nut are increasing from a 3/4" diameter to a 1" diameter, a new pivot bolt collar has been added, and the bolt head is now welded to the bracket housing. These changes are an effort to increase rigidity in a high stress zone, which will improve performance and increase product life.

The new 1" pivot bolt is now required to be torqued to 445-455 Ft. Lbs. (+175 Ft. Lbs. versus 3/4" diameter bolt)

Below outlines the changes to the pivot bolt and service replacement parts kits.

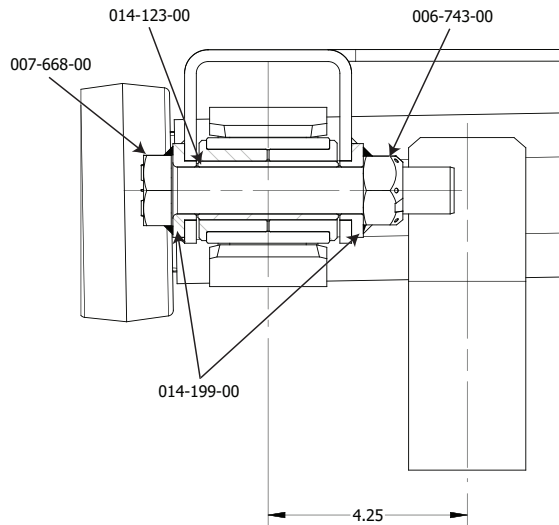

The existing Front Bushing Replacement Kit K71-734-00 is no longer available and has been replaced by K71-734-01. The new kit only includes the 1" pivot bolt and nut, collar, and replacement bushing. Instructions will be included with the necessary steps to upgrade to the 1" pivot bolt and nut.

K71-734-01 (NEW)		
QTY	PART NUMBER	DESCRIPTION
2	006-743-00	LOCKNUT 1-8 UNC GRADE C - ZINC
2	007-668-00	BOLT, HEX 1-8 UNC X 6" GRADE 8 - ZINC
2	014-123-00	PIVOT BUSHING ASSEMBLY
4	014-199-00	PIVOT CONNECTION COLLAR

The new Airflex front pivot bushing and hardware is a running change on new axles.

Please contact your Dexter Account Manager for additional information and further assistance.

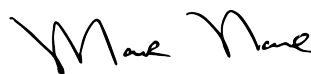

Mark Nave
Market Manager